

PARTS LIST			
ITEM	PART#	DESCRIPTION	NOTES
1	K1290/95	Series 3 Access Body w/ Radius Slide Cover	Assembly
2	1200	Series 2/3 Reveal	Attaches to the Body
3	K1220	Series 3 Rectangle Post	Assembly
4	Post Cap	Series 3 Rectangle Post Cap	Zero Reveal #5010, 3/8" Reveal #5012, 3/4" Reveal #5014
41	5040	Cap Screw	#10 Countersink

Ship To:
Sales Order#

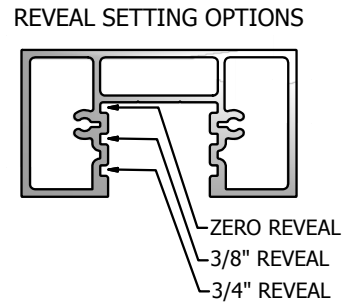
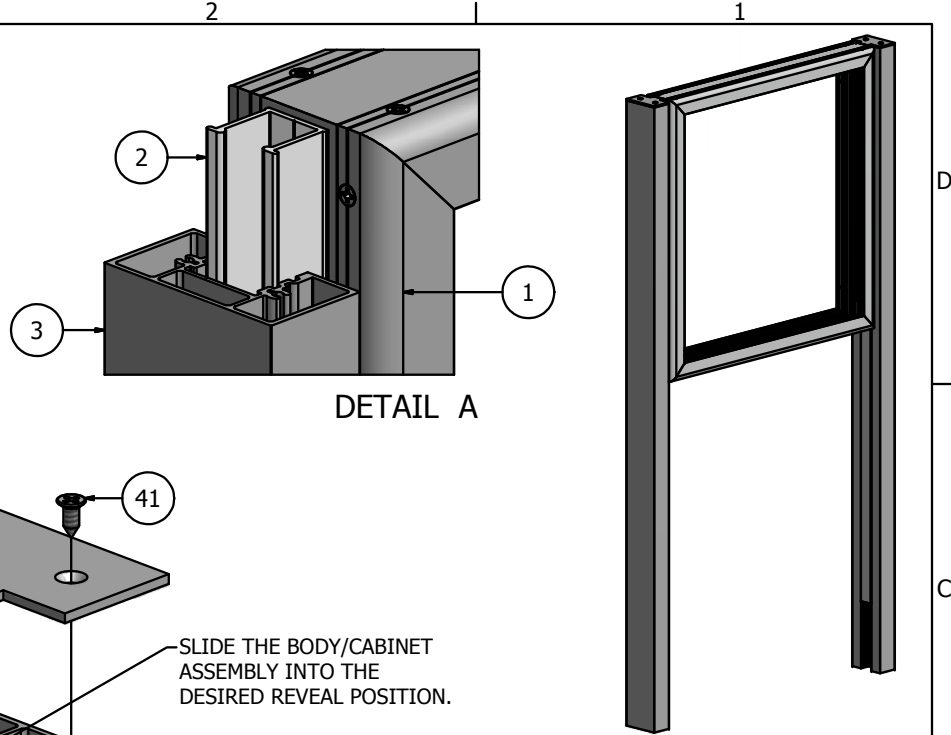
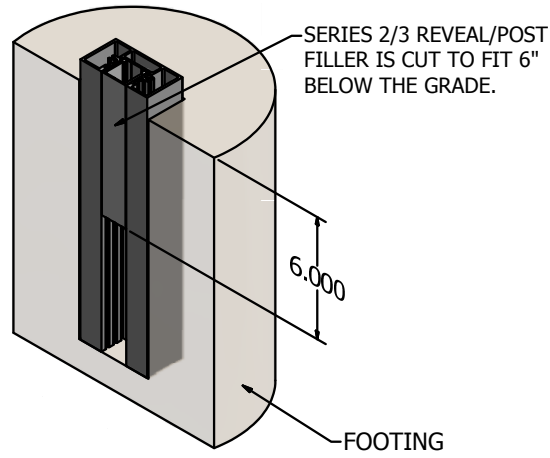
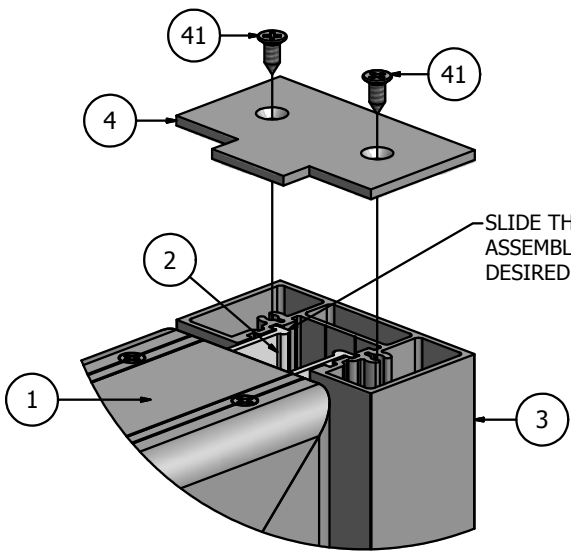
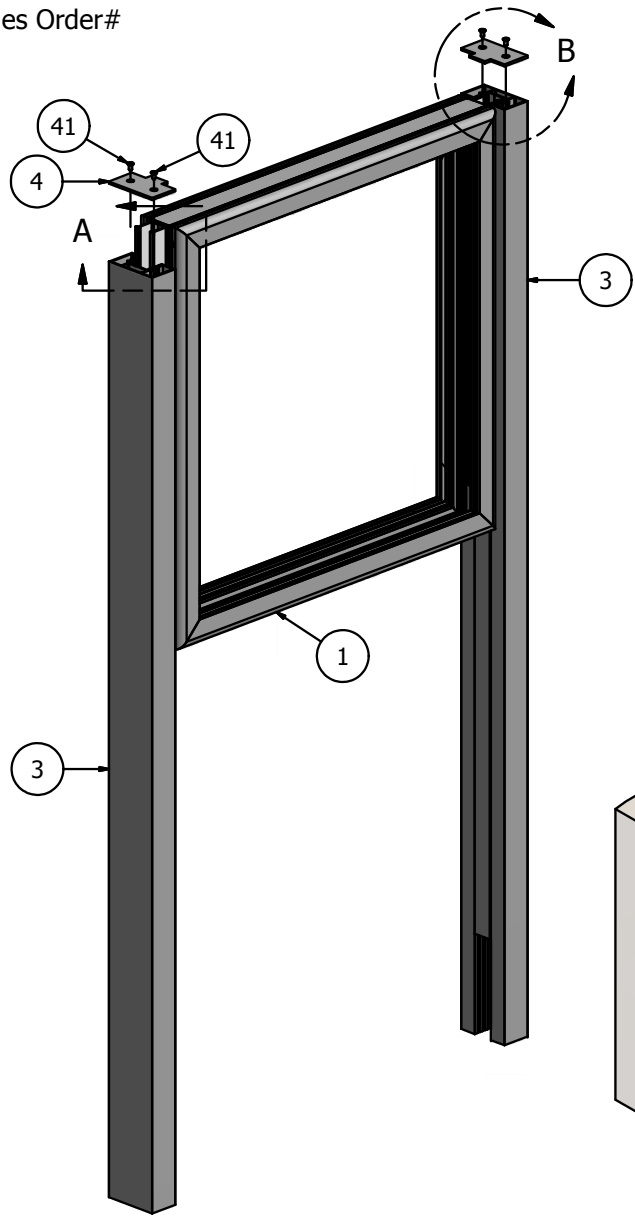

NOTE: PRE-CUT KITS ARE NOT PRE-DRILLED.
(Holes shown in this drawing are for reference only. Drilling of pilot holes are to be done by fabricator.)

THIS DRAWING WAS CREATED AT NO CHARGE TO ASSIST YOU IN VISUALIZING OUR PROPOSAL. THE DRAWING HEREIN IS THE PROPERTY OF SIGNCOMP. PERMISSION TO COPY OR REVISE THIS DRAWING OR TO USE THIS DRAWING FOR PRODUCTION IS STRICTLY PROHIBITED AND CAN ONLY BE COPIED, REVISED OR USED FOR PRODUCTION WITH THE EXPRESSED WRITTEN PERMISSION OF SIGNCOMP.		
DRAWN	SBreihof	10/2/2012
Centroid X:	0.000 in	
Centroid Y:	0.000 in	
Principal Moments Ix:	0.000 in ⁴	
Principal Moments Iy:	0.000 in ⁴	
Section Modulus Ix:	0.000 in ³	
Section Modulus Iy:	0.000 in ³	
SignComp TITLE Series 3 - Access Body w/ Radius Slide Cover - Series 3 Rectangle Post - Assembly		REV
		DWG NO K1290/95/20
SHEET 1 OF 1		

PARTS LIST			
ITEM	PART#	DESCRIPTION	NOTES
1	1290	Series 3 Access Body	Top & Bottom
2	1290	Series 3 Access Body	Sides
60	5241	Access Body Corner Screw	See Hole Detail
6	5339	Series 3 Access Body Corner Angle	One (1) per body corner

Ship To:
Sales Order #

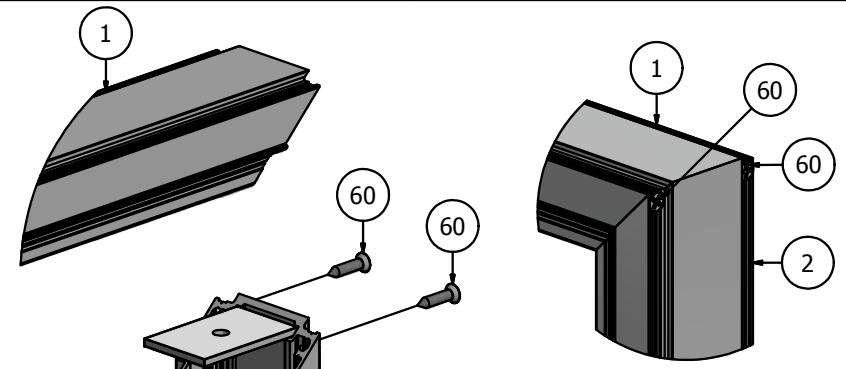
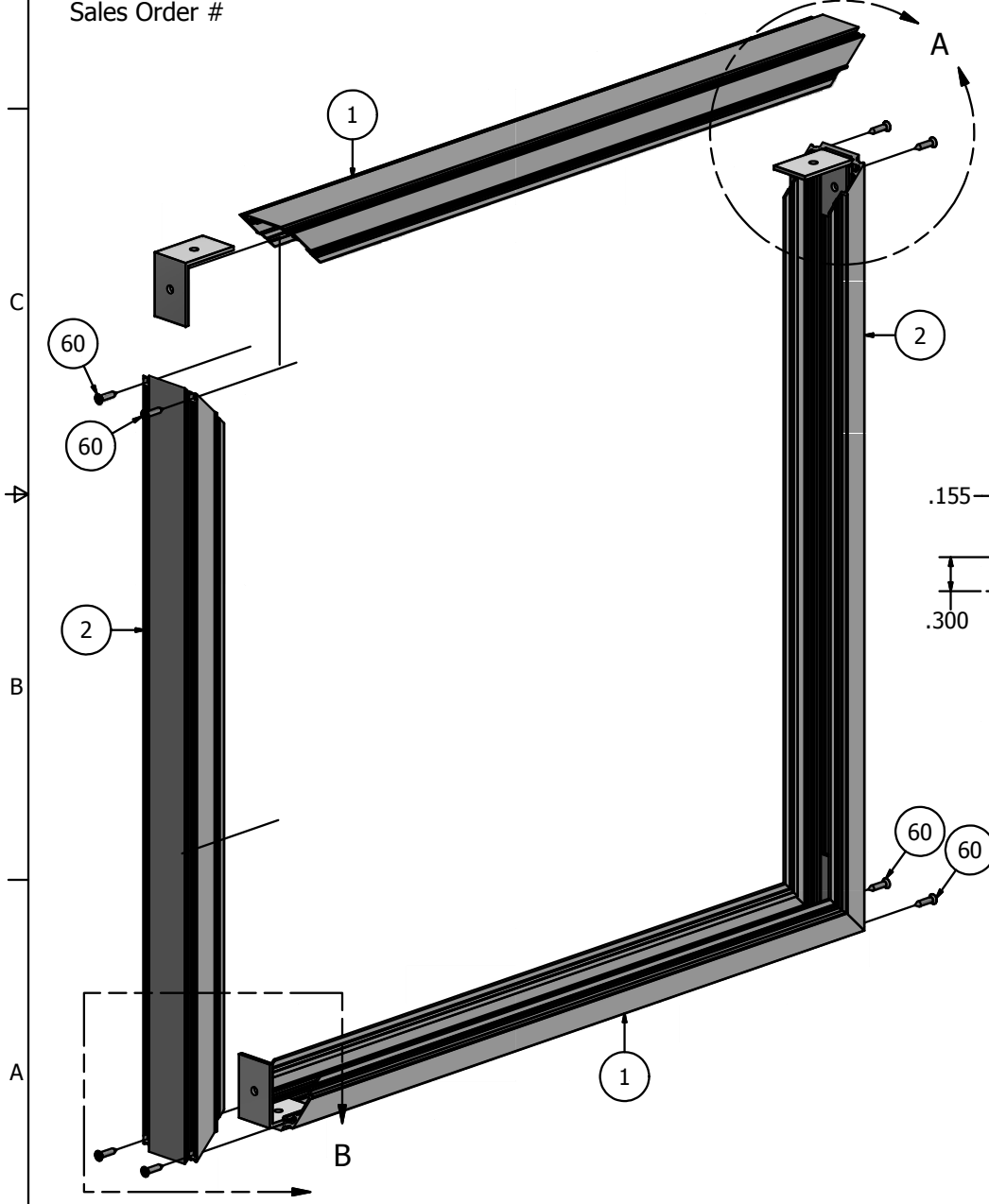

DETAIL A-1

DETAIL A-2

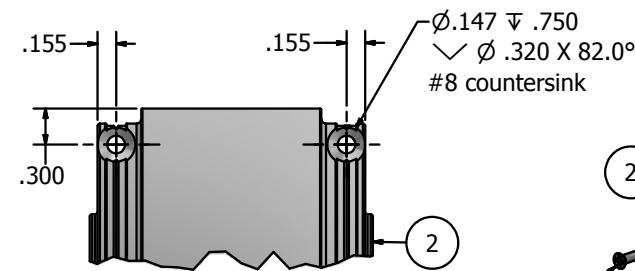

HOLE DETAIL
DRILLED BY OTHER

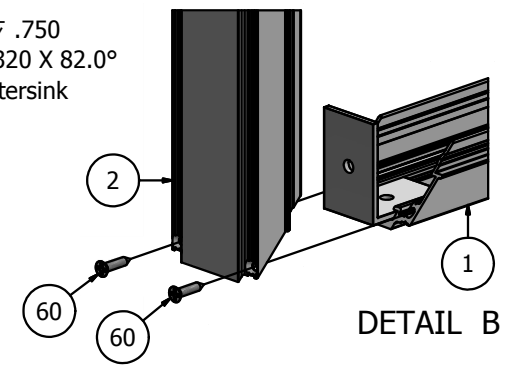

DETAIL B

NOTE: PRE-CUT KITS ARE NOT PRE-DRILLED.
(Holes shown in this drawing are for reference only.
Drilling of pilot holes are to be done by fabricator.)

THIS DRAWING WAS CREATED AT NO CHARGE TO ASSIST YOU IN VISUALIZING OUR PROPOSAL. THE DRAWING HEREIN IS THE PROPERTY OF SIGNCOMP. PERMISSION TO COPY OR REVISE THIS DRAWING OR TO USE THIS DRAWING FOR PRODUCTION IS STRICTLY PROHIBITED AND CAN ONLY BE COPIED, REVISED OR USED FOR PRODUCTION WITH THE EXPRESSED WRITTEN PERMISSION OF SIGNCOMP.		
DRAWN	SBreihof	9/7/2012
Centroid X:	0.000 in	
Centroid Y:	0.000 in	
Principal Moments Ix:	0.000 in^4	
Principal Moments Iy:	0.000 in^4	
Section Modulus Ix:	0.000 in^3	
Section Modulus Iy:	0.000 in^3	
<div style="text-align: center;">SignComp</div>		TITLE
		Series 3 - Access Body
DWG NO		REV
K1290		
SHEET 1 OF 1		

PARTS LIST			
ITEM	PART#	DESCRIPTION	NOTES
1	1290	Series 3 Access Body Assembly	
2	1695	Radius Slide Cover	
3	5226	3/4" Corner Key	
71	5168	Radius Cover Screw	Drill #8 Countersink

Ship To:
Sales Order#

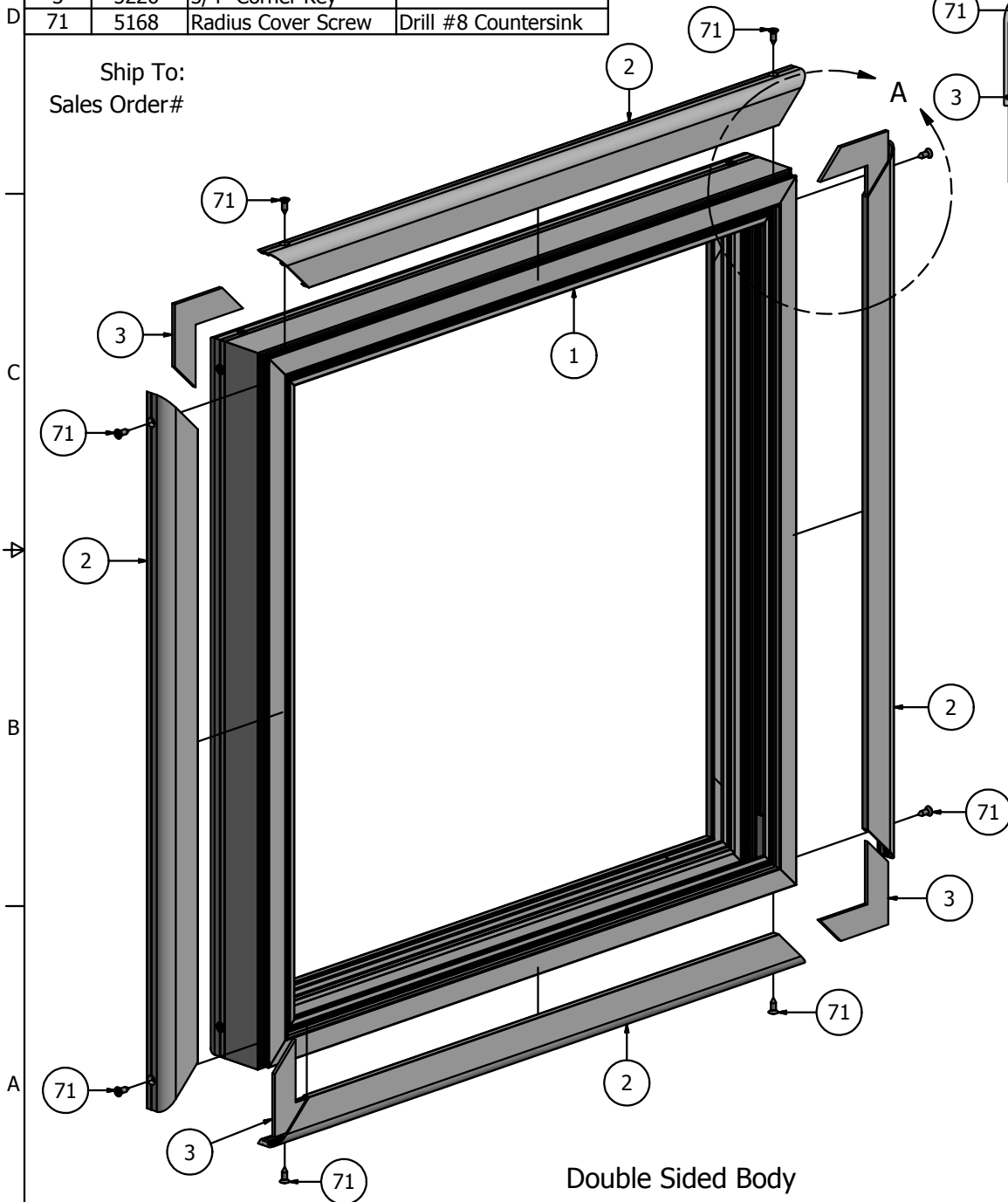

Double Sided Body

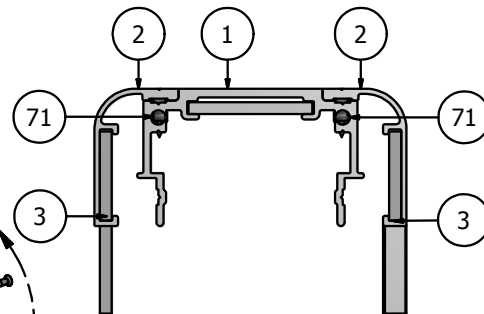

CABINET CROSS-SECTION VIEW

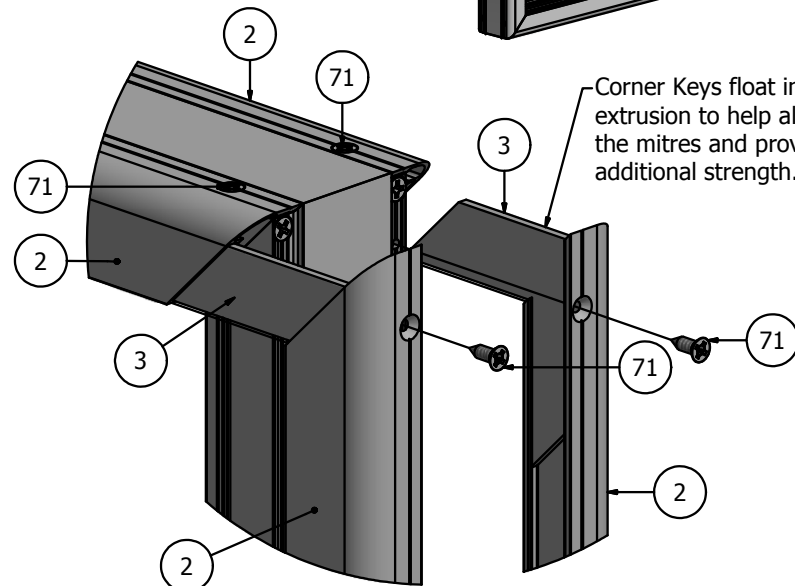
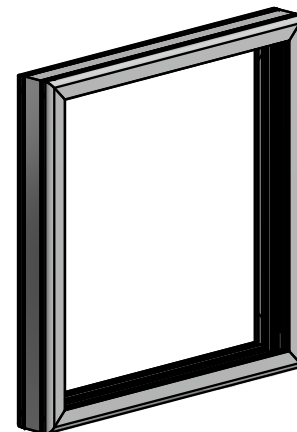

DETAIL A

Corner Keys float in the extrusion to help align the mitres and provide additional strength.

NOTE: PRE-CUT KITS ARE NOT PRE-DRILLED.

(Holes shown in this drawing are for reference only. Drilling of pilot holes are to be done by fabricator.)

THIS DRAWING WAS CREATED AT NO CHARGE TO ASSIST YOU IN VISUALIZING OUR PROPOSAL. THE DRAWING HEREIN IS THE PROPERTY OF SIGNCOMP. PERMISSION TO COPY OR REVISE THIS DRAWING OR TO USE THIS DRAWING FOR PRODUCTION IS STRICTLY PROHIBITED AND CAN ONLY BE COPIED, REVISED OR USED FOR PRODUCTION WITH THE EXPRESSED WRITTEN PERMISSION OF SIGNCOMP.

DRAWN	SBreihof	9/19/2012	SignComp
Centroid X:	0.000 in		
Centroid Y:	0.000 in		TITLE
Principal Moments Ix:	0.000 in ⁴		Series 3 - Access Body w/ Radius Cover - Assembly
Principal Moments Iy:	0.000 in ⁴		DWG NO
Section Modulus Ix:	0.000 in ³		K1290/95
Section Modulus Iy:	0.000 in ³		REV

PARTS LIST			
ITEM	PART#	DESCRIPTION	NOTES
1	K1290/95	Series 3 Access Body and Radius Slide Cover Assembly	Assembly
2	1200	Series 2/3 Reveal	
42	5218	Reveal to Body Screw	Drill 5/32" pilot hole

Ship To:
Sales Order#

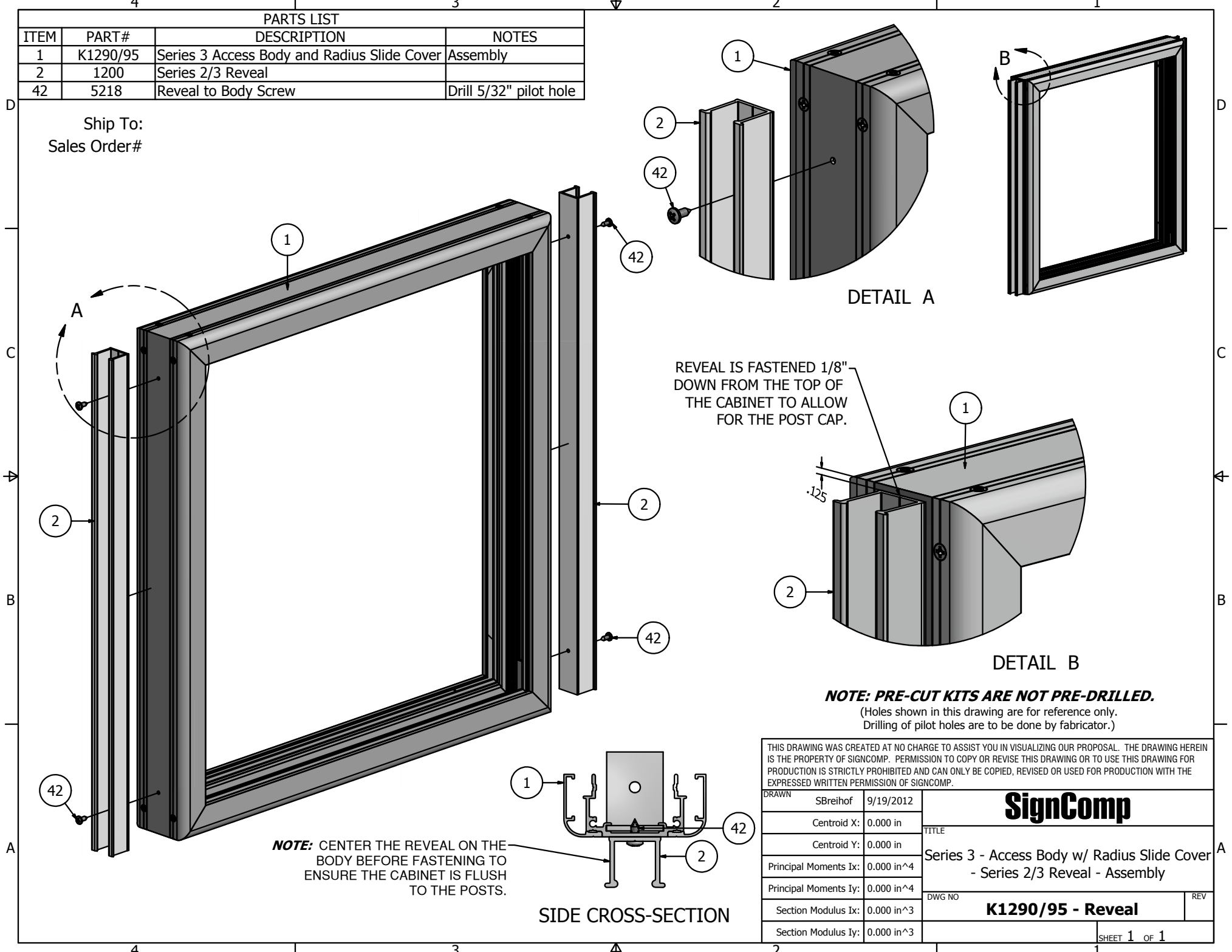

DETAIL A

REVEAL IS FASTENED 1/8" DOWN FROM THE TOP OF THE CABINET TO ALLOW FOR THE POST CAP.

DETAIL B

NOTE: PRE-CUT KITS ARE NOT PRE-DRILLED.
(Holes shown in this drawing are for reference only. Drilling of pilot holes are to be done by fabricator.)

NOTE: CENTER THE REVEAL ON THE BODY BEFORE FASTENING TO ENSURE THE CABINET IS FLUSH TO THE POSTS.

SIDE CROSS-SECTION

THIS DRAWING WAS CREATED AT NO CHARGE TO ASSIST YOU IN VISUALIZING OUR PROPOSAL. THE DRAWING HEREIN IS THE PROPERTY OF SIGNCOMP. PERMISSION TO COPY OR REVISE THIS DRAWING OR TO USE THIS DRAWING FOR PRODUCTION IS STRICTLY PROHIBITED AND CAN ONLY BE COPIED, REVISED OR USED FOR PRODUCTION WITH THE EXPRESSED WRITTEN PERMISSION OF SIGNCOMP.

DRAWN	SBreihof	9/19/2012
Centroid X:	0.000 in	
Centroid Y:	0.000 in	
Principal Moments Ix:	0.000 in ⁴	
Principal Moments Iy:	0.000 in ⁴	
Section Modulus Ix:	0.000 in ³	
Section Modulus Iy:	0.000 in ³	

SignComp	
TITLE	
Series 3 - Access Body w/ Radius Slide Cover - Series 2/3 Reveal - Assembly	
DWG NO	REV
K1290/95 - Reveal	
SHEET 1 OF 1	

Parts List			
ITEM	PART #	DESCRIPTION	NOTES
1	1220	Series 3 Rectangular Post	
2	1200	Series 2/3 Reveal	Tack weld or mechanically fasten to post

Ship To:

Order Number:

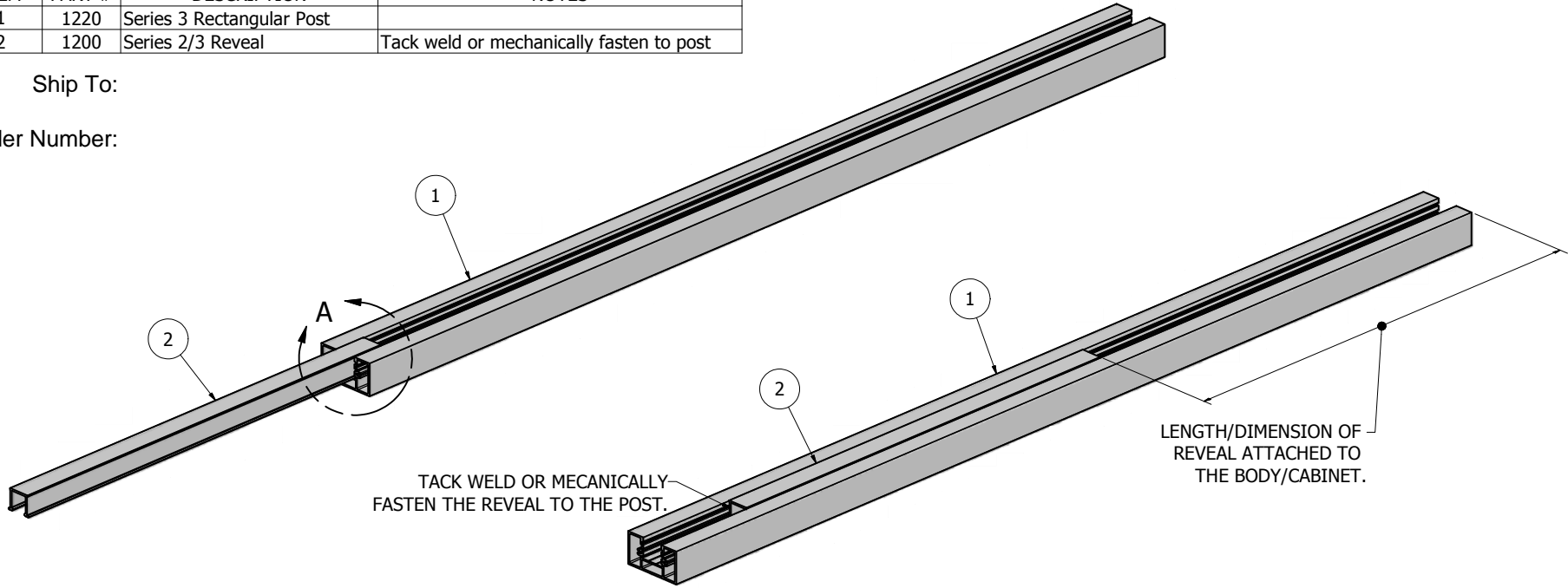

TACK WELD OR MECANICALLY FASTEN THE REVEAL TO THE POST.

LENGTH/DIMENSION OF REVEAL ATTACHED TO THE BODY/CABINET.

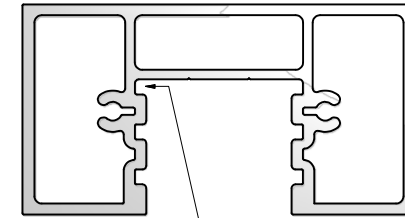

ZERO REVEAL

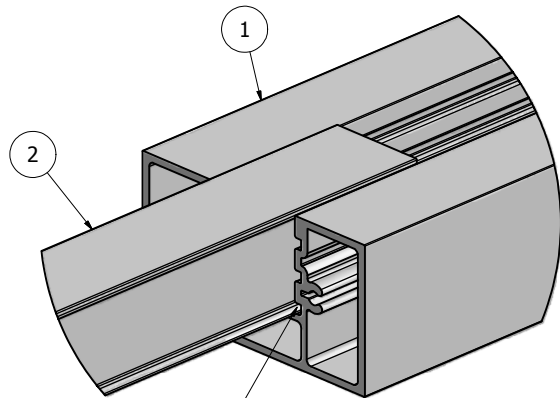

DETAIL A

INSERT THE REVEAL/FILLER INTO THE ZERO REVEAL POSTION. SLIDED IT UP INTO THE POST.

NOTE: PRE-CUT KITS ARE NOT PRE-DRILLED.

(Holes shown in this drawing are for reference only. Drilling of pilot holes are to be done by fabricator.)

THIS DRAWING WAS CREATED AT NO CHARGE TO ASSIST YOU IN VISUALIZING OUR PROPOSAL. THE DRAWING HEREIN IS THE PROPERTY OF SIGNCOMP. PERMISSION TO COPY OR REVISE THIS DRAWING OR TO USE THIS DRAWING FOR PRODUCTION IS STRICTLY PROHIBITED AND CAN ONLY BE COPIED, REVISED OR USED FOR PRODUCTION WITH THE EXPRESSED WRITTEN PERMISSION OF SIGNCOMP.

DRAWN	4/5/2010	SignComp	
Steve			
CHECKED		TITLE	
QA		Series 3, 3-1/4" Rectangular Post - Series 2/3	
MFG		Reveal - Assembly	
APPROVED		SIZE	DWG NO
		C	1220-00
		SCALE	SHEET 1 OF 1